

SPLIT TYPE
ROOM AIR CONDITIONER
WALL MOUNTED TYPE

SERVICE MANUAL



Indoor unit	Outdoor unit
ASYG30LFCA	AOYG30LFT

CONTENTS

SPECIFICATIONS.....	1
DIMENSIONS.....	2
REFRIGERANT SYSTEM DIAGRAM.....	3
CIRCUIT DIAGRAM.....	4
INDOOR PCB CIRCUIT DIAGRAM.....	5
OUTDOOR PCB CIRCUIT DIAGRAM.....	8
ERROR DETECTION.....	13
PARTS (INDOOR UNIT).....	14
PARTS (OUTDOOR UNIT).....	18
ACCESSORIES.....	22

SPECIFICATIONS

ELECTRICAL DATA

TYPE		Cool & heat inverter
INDOOR UNIT		ASYG30LFCA
OUTDOOR UNIT		AOYG30LFT
COOLING CAPACITY		8.00 kW
HEATING CAPACITY		8.80 kW
POWER SOURCE		230 V
FREQUENCY		50 Hz
RUNNING CURRENT	COOLING	10.9 A
	HEATING	10.7 A
INPUT WATTS	COOLING	2.49 kW
	HEATING	2.44 kW
E.E.R.	COOLING	3.21 kW/kW
COP	HEATING	3.61 kW/kW
MOISTURE REMOVAL		3.2 L/hr
AIR CIRCULATION HIGH		1,100 m ³ /hr
MAXIMUM CURRENT	COOLING	17.0 A
	HEATING	19.0 A

FAN MOTOR

POWER SOURCE		230 V
INDOOR UNIT (Cool)	High	1,430 r.p.m.
	Medium	1,220 r.p.m.
	Low	1,020 r.p.m.
	Quiet	900 r.p.m.
INDOOR UNIT (Heat)	High	1,530 r.p.m.
	Medium	1,220 r.p.m.
	Low	1,020 r.p.m.
	Quiet	900 r.p.m.
OUTDOOR UNIT (Cool)		850 r.p.m.
OUTDOOR UNIT (Heat)		850 r.p.m.

NOISE LEVEL

INDOOR UNIT (Cool)	High	48 dB
	Medium	42 dB
	Low	37 dB
	Quiet	33 dB
INDOOR UNIT (Heat)	High	49 dB
	Medium	42 dB
	Low	37 dB
	Quiet	33 dB
OUTDOOR UNIT (Cool)		53 dB
OUTDOOR UNIT (Heat)		55 dB

COMPRESSOR AND REFRIGERANT

TYPE	Hermetic type, 4 pole, Rotary, DC inverter motor	
DISCRIMINATION	N-TF30ND1A	
WEIGHT WITH OIL	15.5 kg	
PRECHARGED REFRIGERANT	2,100 g	
REFRIGERANT TYPE	R410A	
FULL CHARGE	Pipe length 20 m	2,100 g
	50 m	3,300 g
ADDITIONAL CHARGE	40 g/m	
MAXIMUM HEIGHT	30 m	

DIMENSIONS

INDOOR UNIT	H x W x D	320 x 998 x 238 mm
OUTDOOR UNIT	H x W x D	830 x 900 x 330 mm

WEIGHT

INDOOR UNIT	Shipping / Net	18 kg / 14 kg
OUTDOOR UNIT	Shipping / Net	68 kg / 61 kg

DIMENSIONS

(unit : mm)

INDOOR UNIT

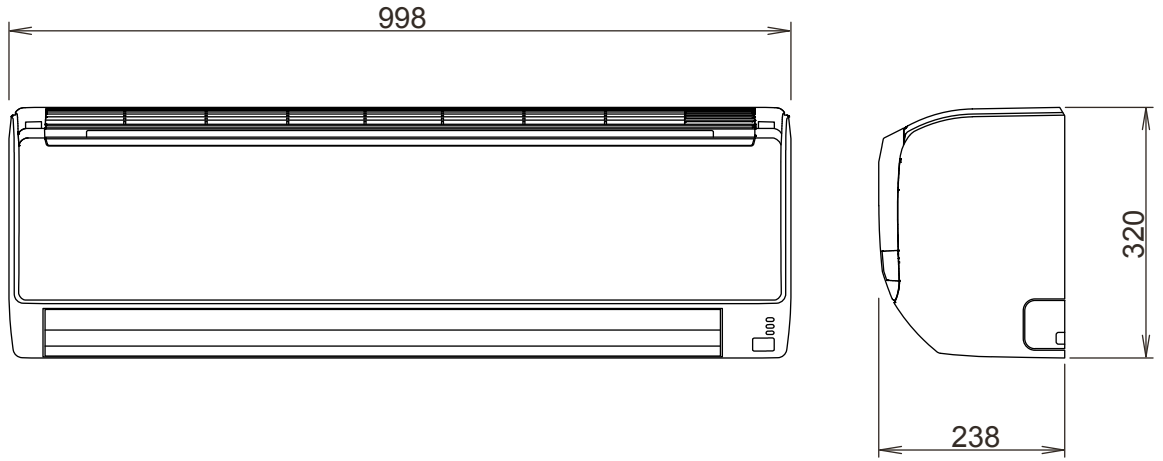

OUTDOOR UNIT

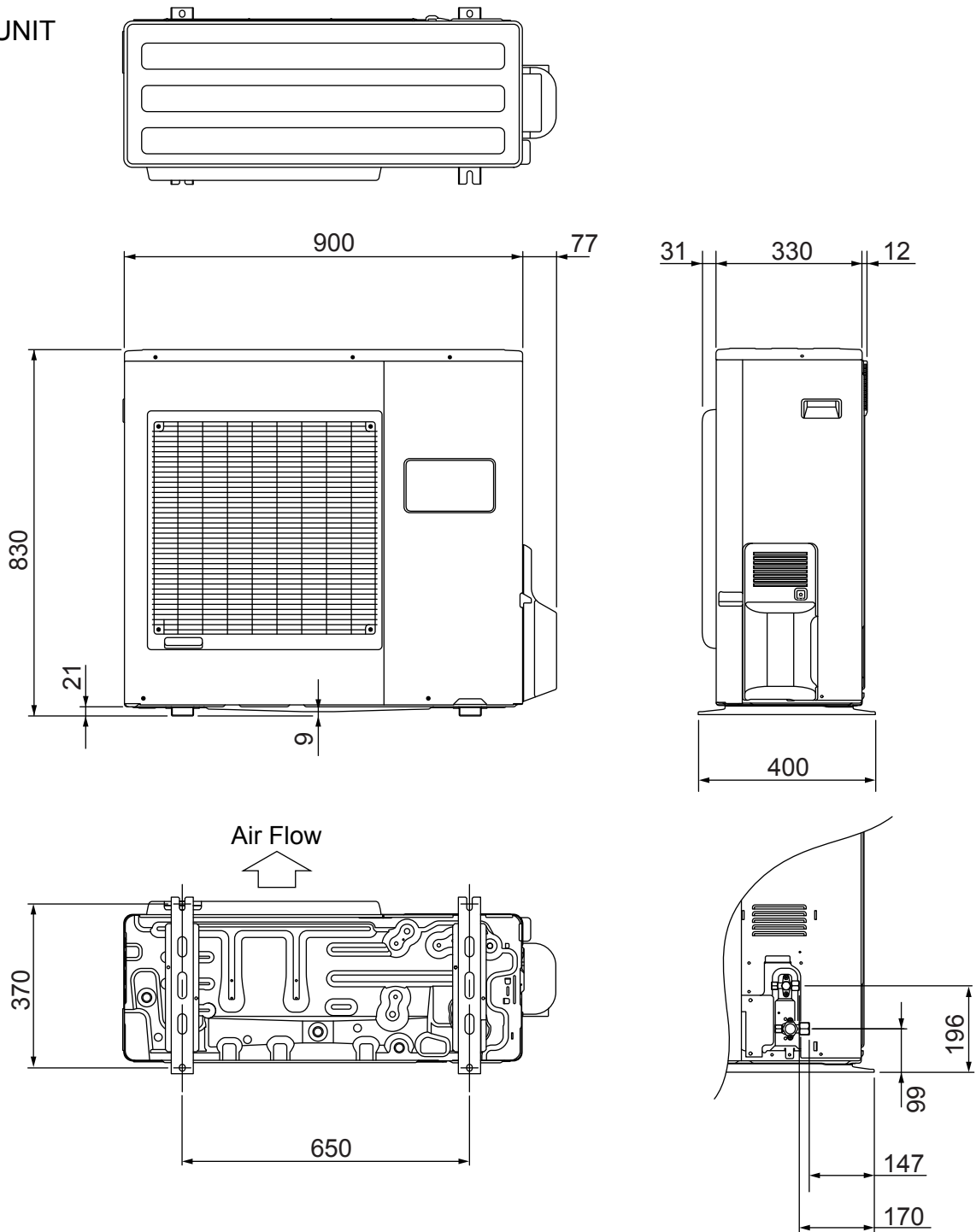

REFRIGERANT SYSTEM DIAGRAM

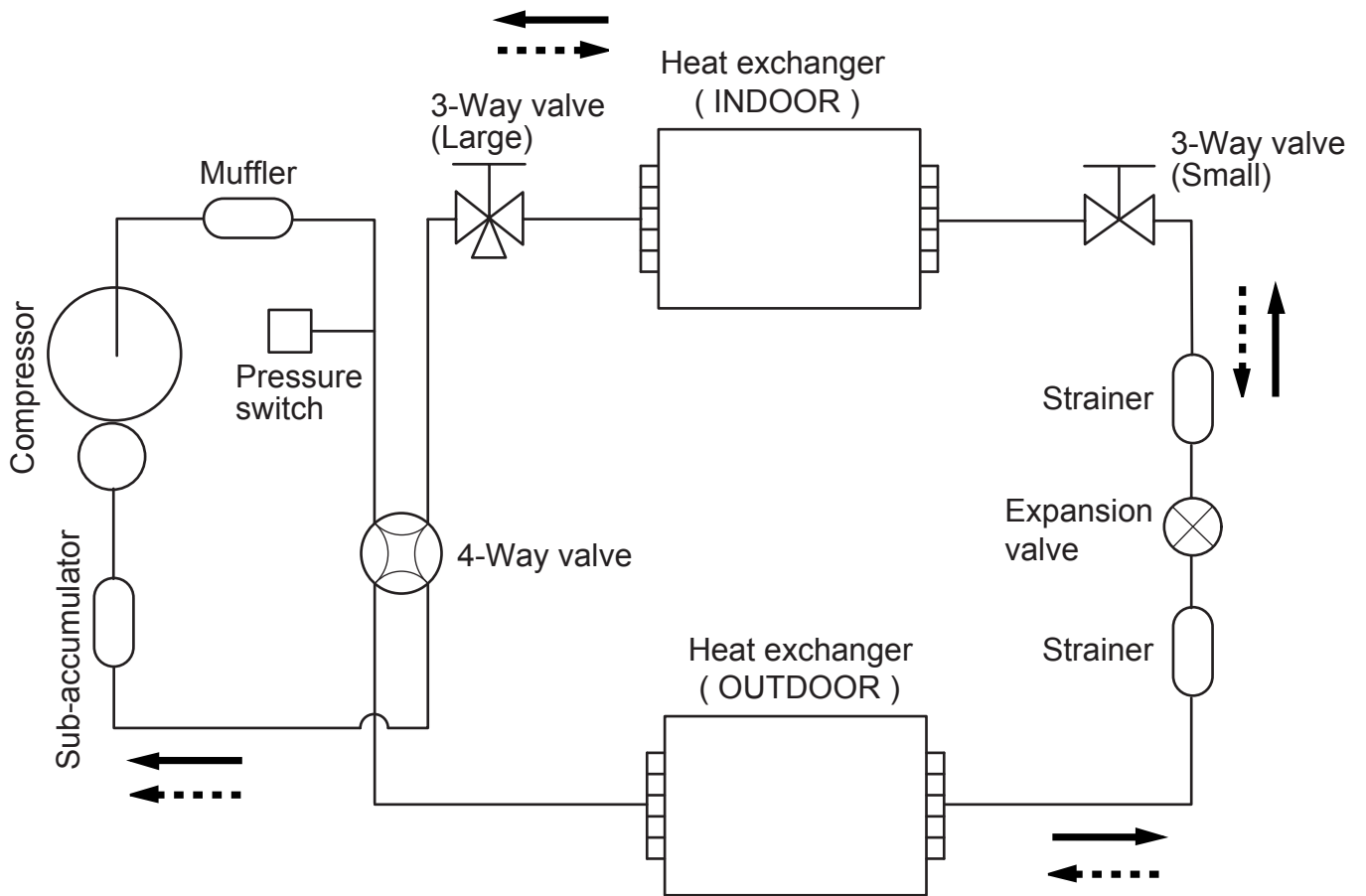

———→ Cooling
 - - - -> Heating

Refrigerant pipe diameter
 Liquid : 3/8" (9.52 mm)
 Gas : 5/8" (15.88 mm)

INDOOR PCB CIRCUIT DIAGRAM

CONTRO UNIT
EZ-0101CHSE

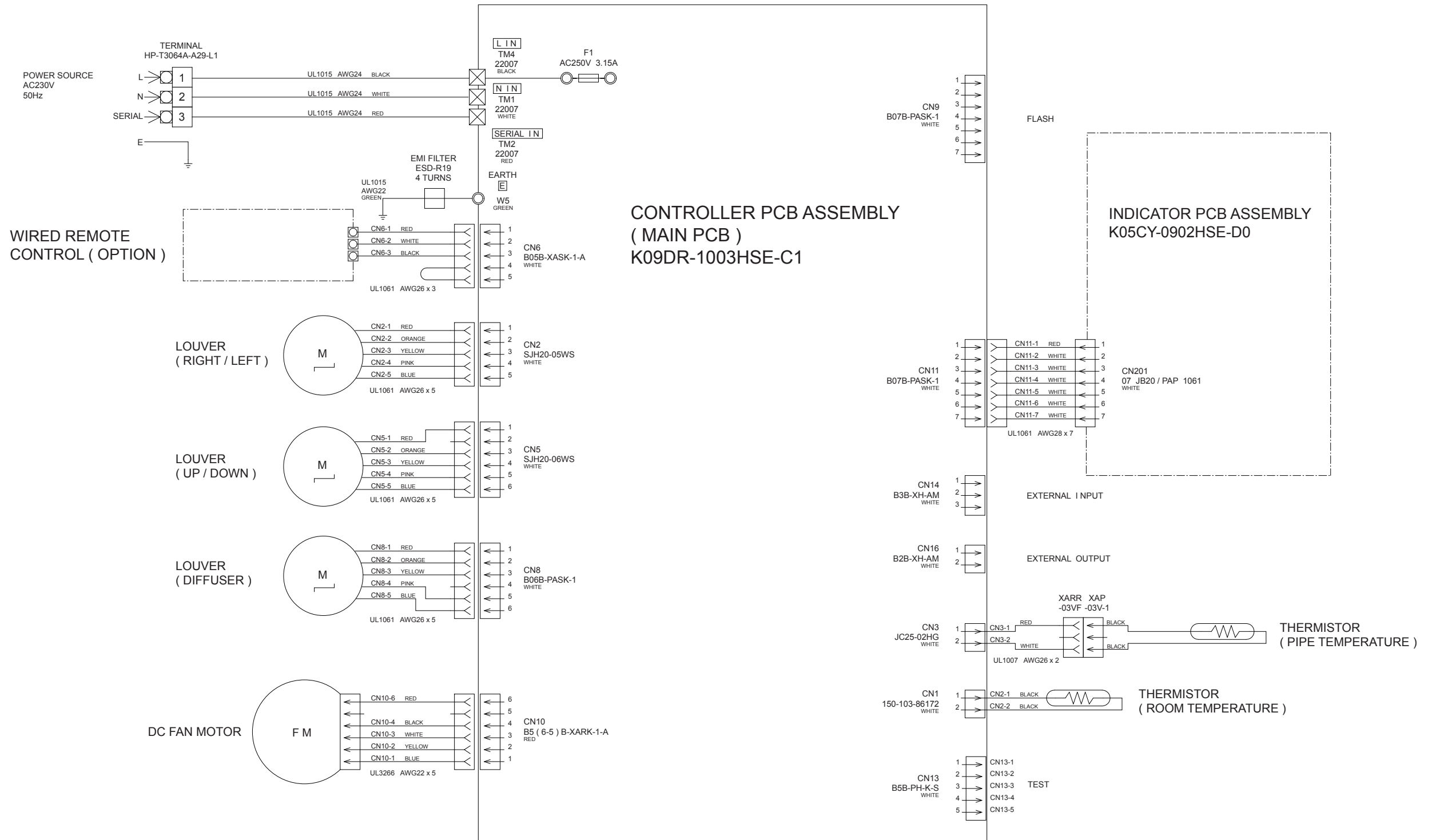

INDOOR UNIT
 INDICATOR PCB ASSEMBLY
 K05CY-0902HSE-D0

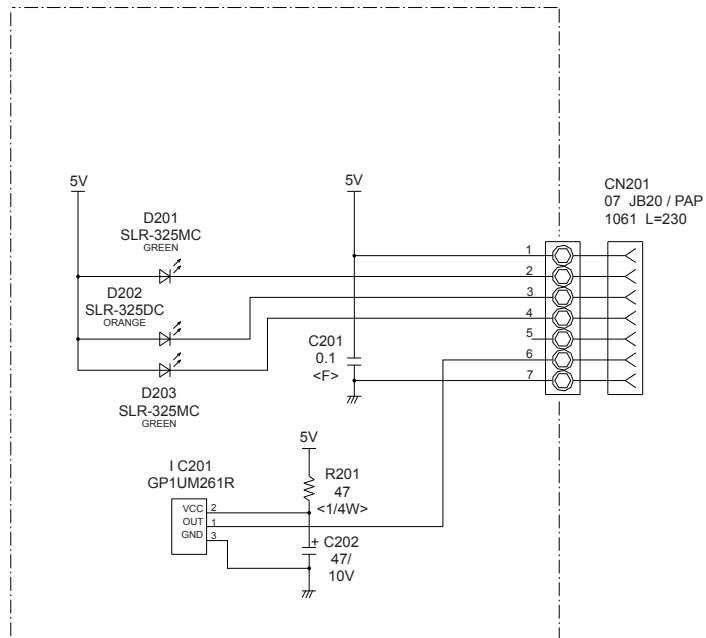

OUTDOOR PCB CIRCUIT DIAGRAM

INVERTER ASSEMBLY EZ-0101LHUE

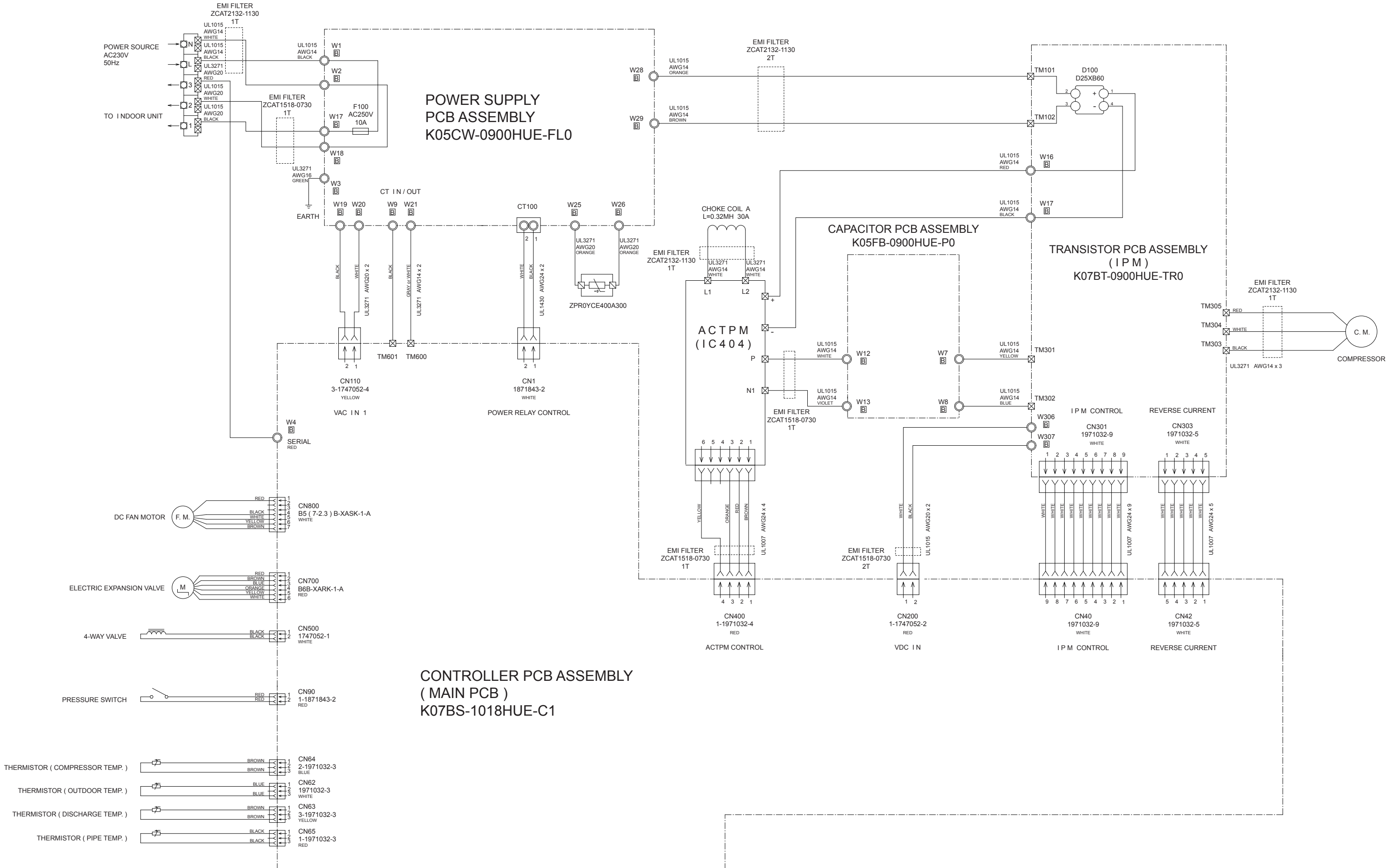

OUTDOOR UNIT CONTROLLER PCB ASSEMBLY (MAIN PCB) K07BS-1018HUE-C1

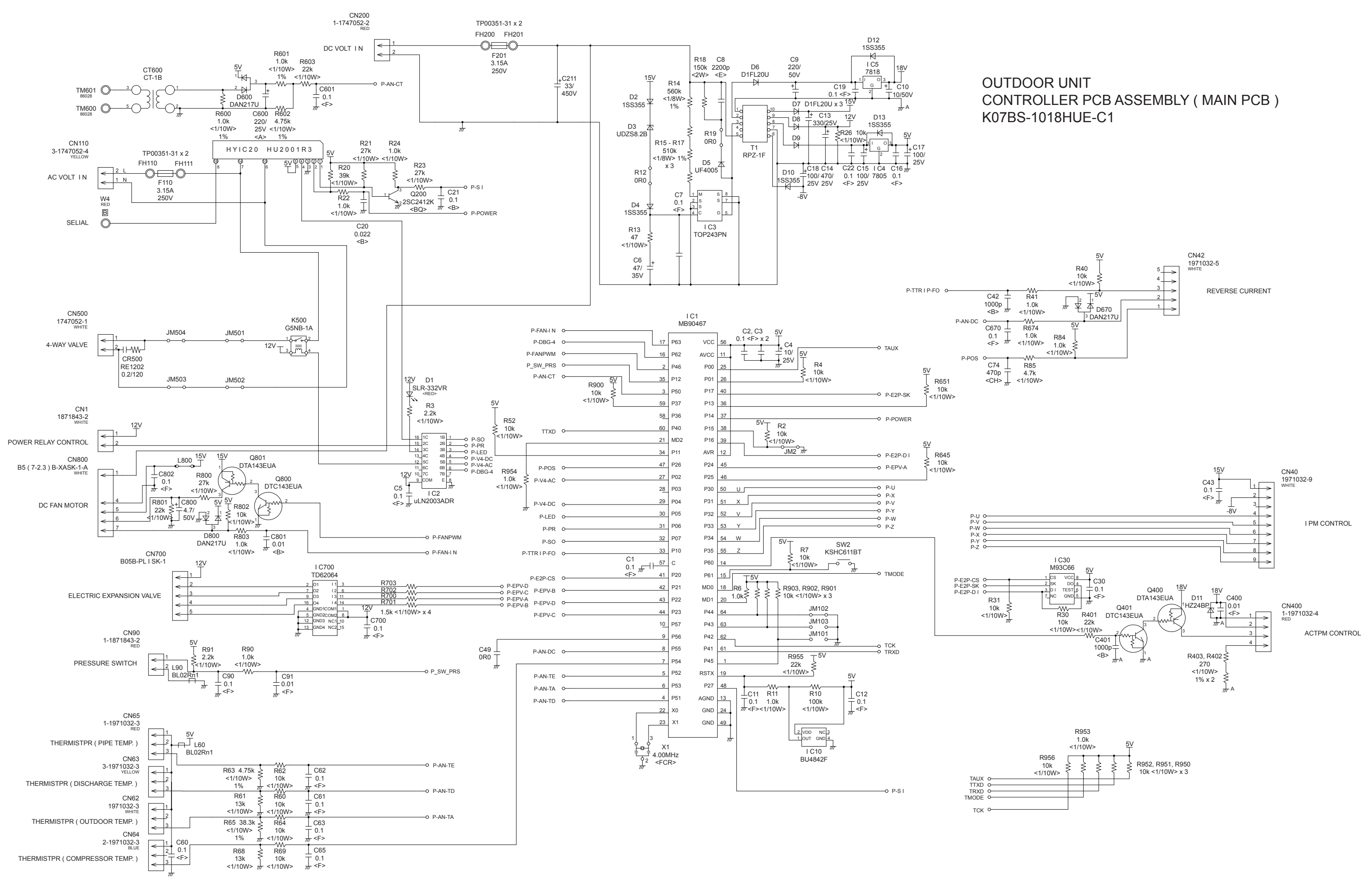

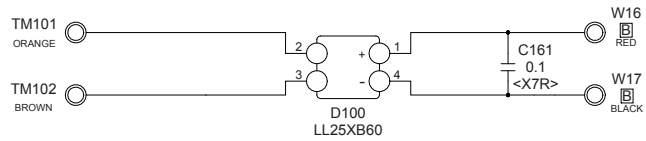

OUTDOOR UNIT TRANSISTOR PCB ASSEMBLY (I P M) K07BT-0900HUE-TR0

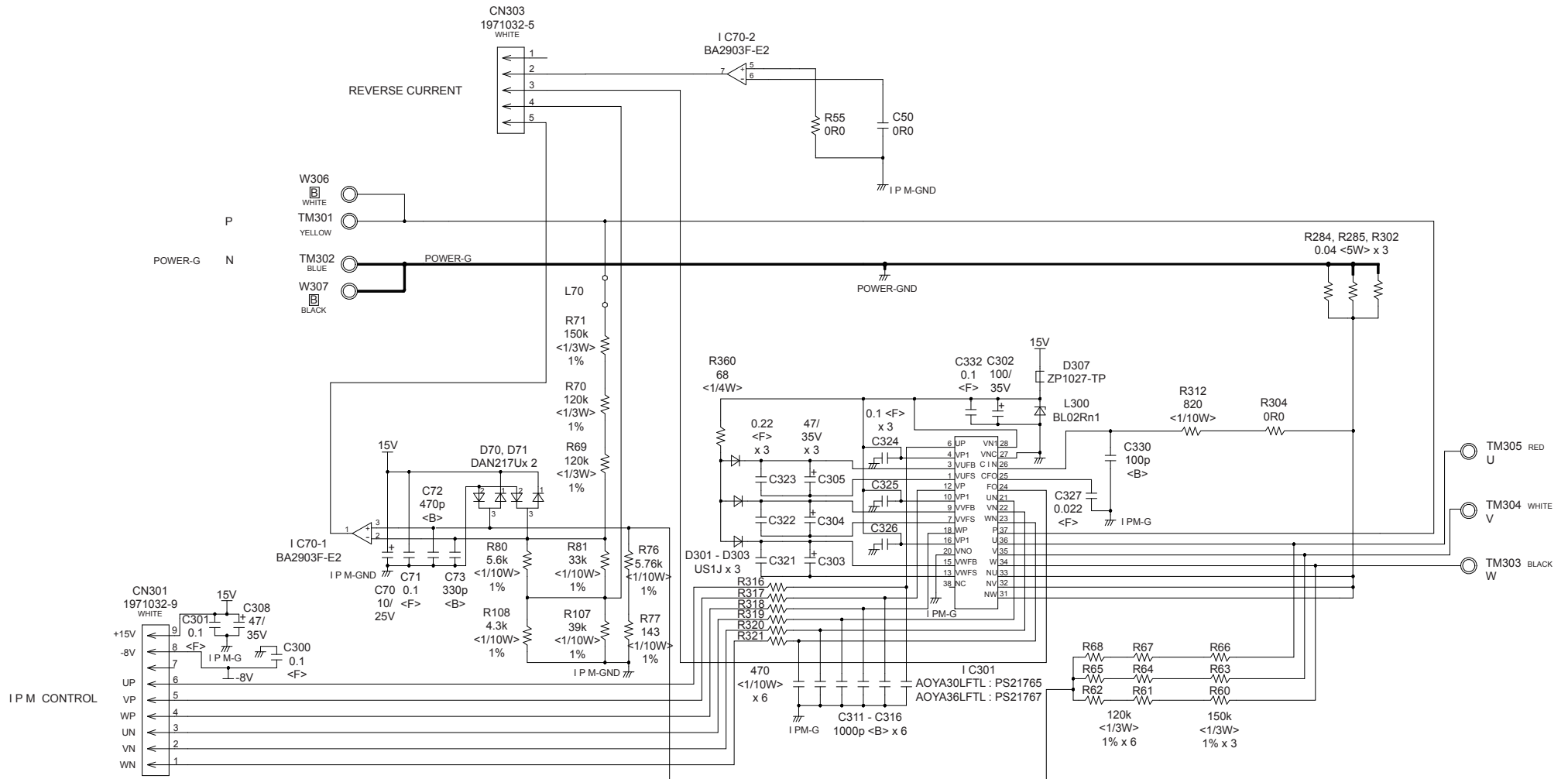

OUTDOOR UNIT POWER SUPPLY PCB ASSEMBLY K05CW-0900HUE-FL0

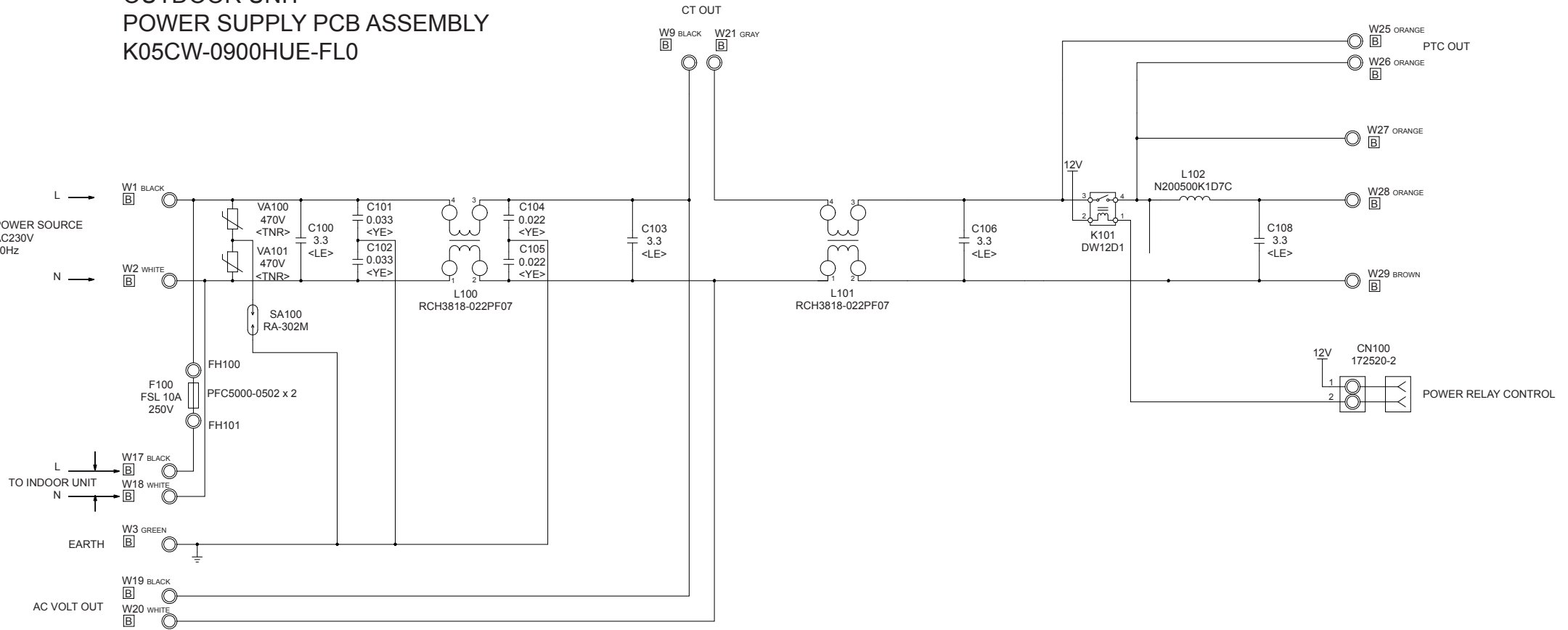

OUTDOOR UNIT
CAPACITOR PCB ASSEMBLY
K05FB-0900HUE-P0

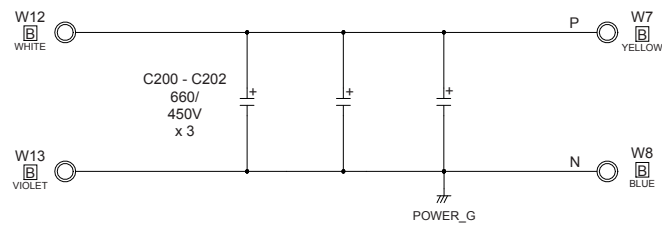

- : 0.5s on / 0.5s off
- ◇ : 0.1s on / 0.1s off
- () : Number of flashing

ERROR DETECTION

INDOOR UNIT and WIRED REMOTE CONTROL

If you use a wireless remote control, the lamp on the photo detector unit will output error codes by way of blinking patterns.

If you use a wired type remote control, error codes will appear on the remote control display. See the lamp blinking patterns and error codes in the table. An error display is displayed only during running.

Troubleshooting with the wired remote control.

If an error occurs, the following display will be shown. ("Er" will appear in the set room temperature display.)

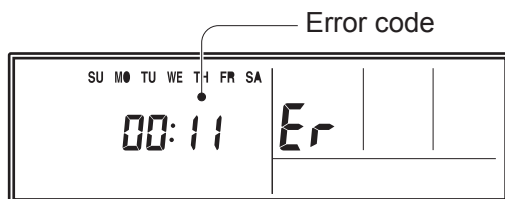

EX. Self-diagnosis

Indoor unit			Wired remote control	Description
OPERATION lamp (green)	TIMER lamp (orange)	ECONOMY lamp (green)		
●(1)	●(1)	◇	11	Serial communication error
●(1)	●(2)	◇	12	Wired remote control communication error
●(1)	●(5)	◇	15	Check run unfinished
●(2)	●(1)	◇	21	Unit number or Refrigerant circuit address setting error [Simultaneous Multi]
●(2)	●(2)	◇	22	Indoor unit capacity error
●(2)	●(3)	◇	23	Combination error
●(2)	●(4)	◇	24	• Connection unit number error (indoor slave unit) [Simultaneous Multi] • Connection unit number error (indoor unit or branch unit) [Flexible Multi]
●(2)	●(7)	◇	27	Master unit, slave unit set-up error [Simultaneous Multi]
●(3)	●(2)	◇	32	Indoor unit PCB model information error
●(3)	●(5)	◇	35	Manual auto switch error
●(4)	●(1)	◇	41	Inlet air temp. sensor error
●(4)	●(2)	◇	42	Indoor unit Heat Ex. Middle temp. sensor error
●(5)	●(1)	◇	51	Indoor unit fan motor error
●(5)	●(3)	◇	53	Drain pump error
●(5)	●(7)	◇	57	Damper error
●(5)	●(15)	◇	5U	Indoor unit error
●(6)	●(2)	◇	62	Outdoor unit main PCB model information error or communication error
●(6)	●(3)	◇	63	Inverter error
●(6)	●(4)	◇	64	Active filter error, PFC circuit error
●(6)	●(5)	◇	65	Trip terminal L error
●(6)	●(10)	◇	6A	Display PCB microcomputers communication error
●(7)	●(1)	◇	71	Discharge temp. sensor error
●(7)	●(2)	◇	72	Compressor temp. sensor error
●(7)	●(3)	◇	73	Outdoor unit Heat Ex. liquid temp. sensor error
●(7)	●(4)	◇	74	Outdoor temp. sensor error
●(7)	●(5)	◇	75	Suction Gas temp. sensor error
●(7)	●(6)	◇	76	• 2-way valve temp. sensor error • 3-way valve temp. sensor error
●(7)	●(7)	◇	77	Heat sink temp. sensor error
●(8)	●(2)	◇	82	• Sub-cool Heat Ex. gas inlet temp. sensor error • Sub-cool Heat Ex. gas outlet temp. sensor error
●(8)	●(3)	◇	83	Liquid pipe temp. sensor error
●(8)	●(4)	◇	84	Current sensor error
●(8)	●(6)	◇	86	• Discharge pressure sensor error • Suction pressure sensor error • High pressure switch error
●(9)	●(4)	◇	94	Trip detection
●(9)	●(5)	◇	95	Compressor rotor position detection error (permanent stop)
●(9)	●(7)	◇	97	Outdoor unit fan motor error
●(9)	●(9)	◇	99	4-way valve error
●(10)	●(1)	◇	A1	Discharge temp. error
●(10)	●(3)	◇	A3	Compressor temp. error
●(10)	●(4)	◇	A4	High pressure error
●(10)	●(5)	◇	A5	Low pressure error
●(13)	●(2)	◇	J2	Branch boxes error [Flexible Multi]

PARTS

INDOOR UNIT

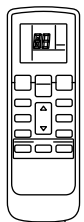
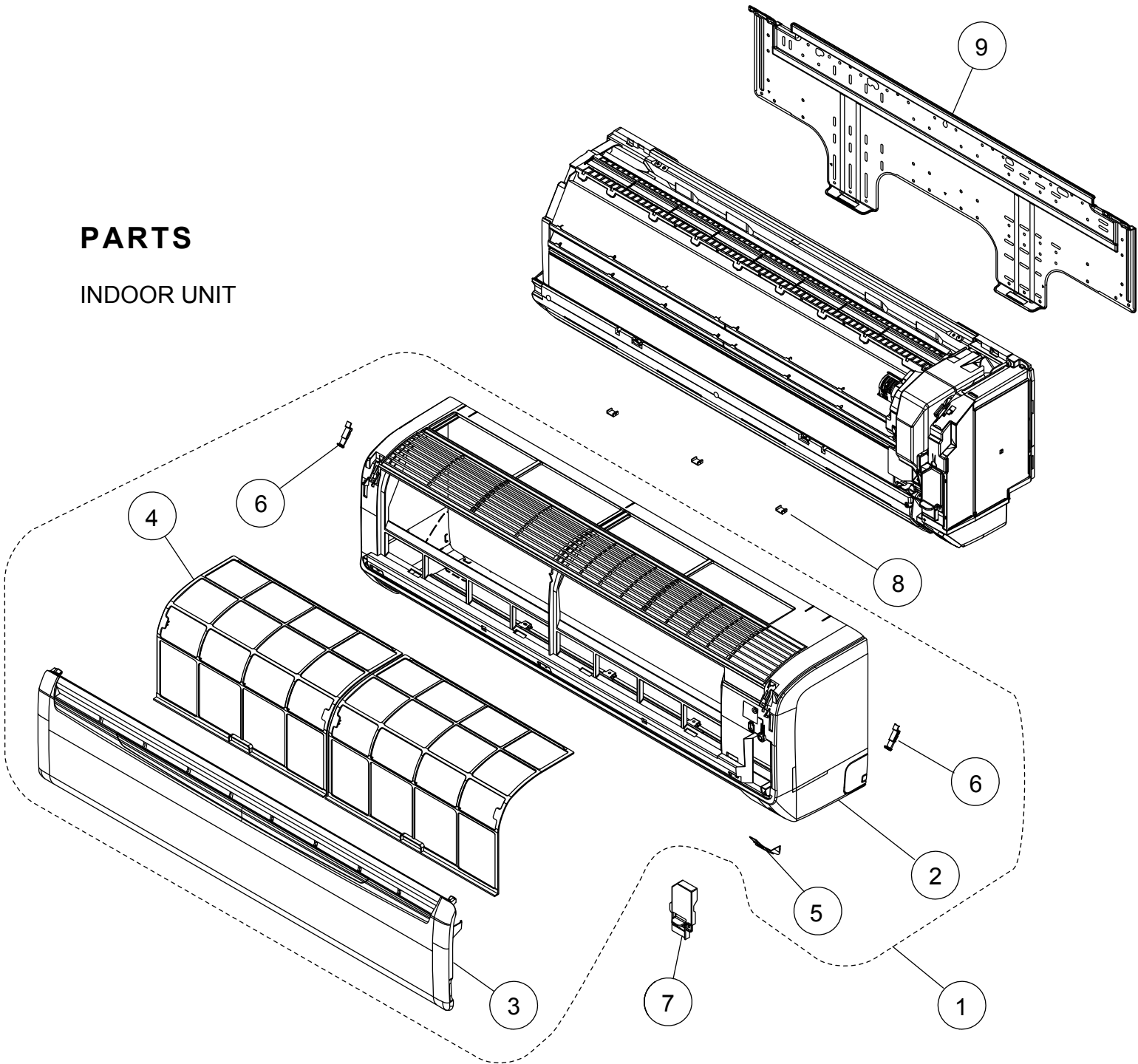

10

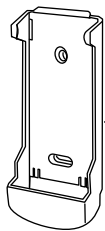

11

Ref	Description	Parts number
1	Front Panel Total Assy	9318738001
2	Front Panel	9314991080
3	Intake Grille Assy	9385985049
4	Air Filter	9315014016
5	Receiver Window	9315010018
6	Clamber Grille	9306755010
7	Wire Clamber	9315015013
8	Cap (Screw)	9309002050
9	Bracket Panel	9315023018
10	Remote Control	9379219037
11	Remote Control Holder	9305642045
--	Air Clean Filter Assy	9315212016

INDOOR UNIT

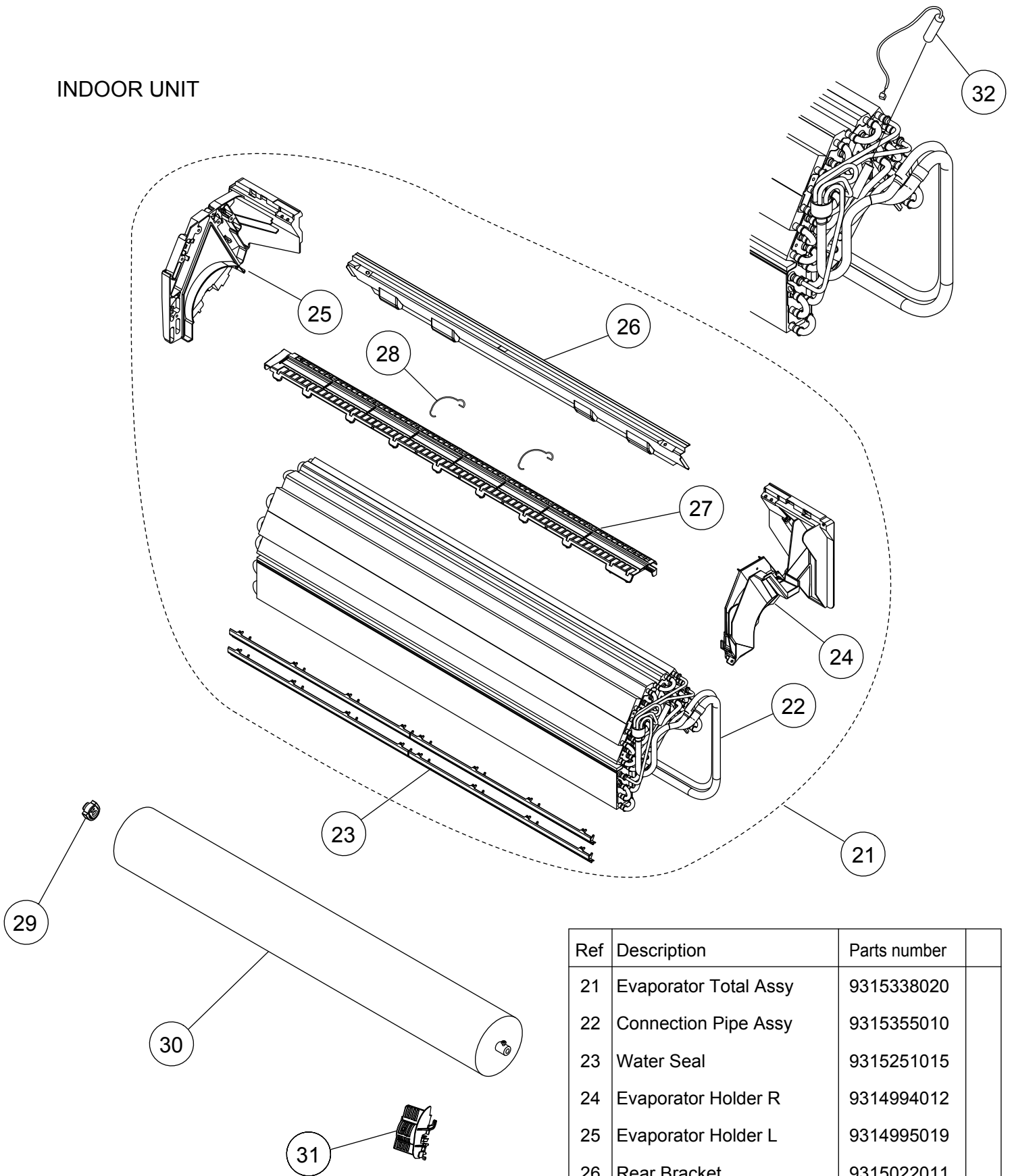

Ref	Description	Parts number
21	Evaporator Total Assy	9315338020
22	Connection Pipe Assy	9315355010
23	Water Seal	9315251015
24	Evaporator Holder R	9314994012
25	Evaporator Holder L	9314995019
26	Rear Bracket	9315022011
27	Filter Guide	9315013019
28	Filter Guard	9315411013
29	Bearing C Assy	9306628017
30	Crossflow Fan Assy	9315024015
31	Holder (Room Thermistor)	9315252012
32	Pipe Thermistor	9900551018

INDOOR UNIT

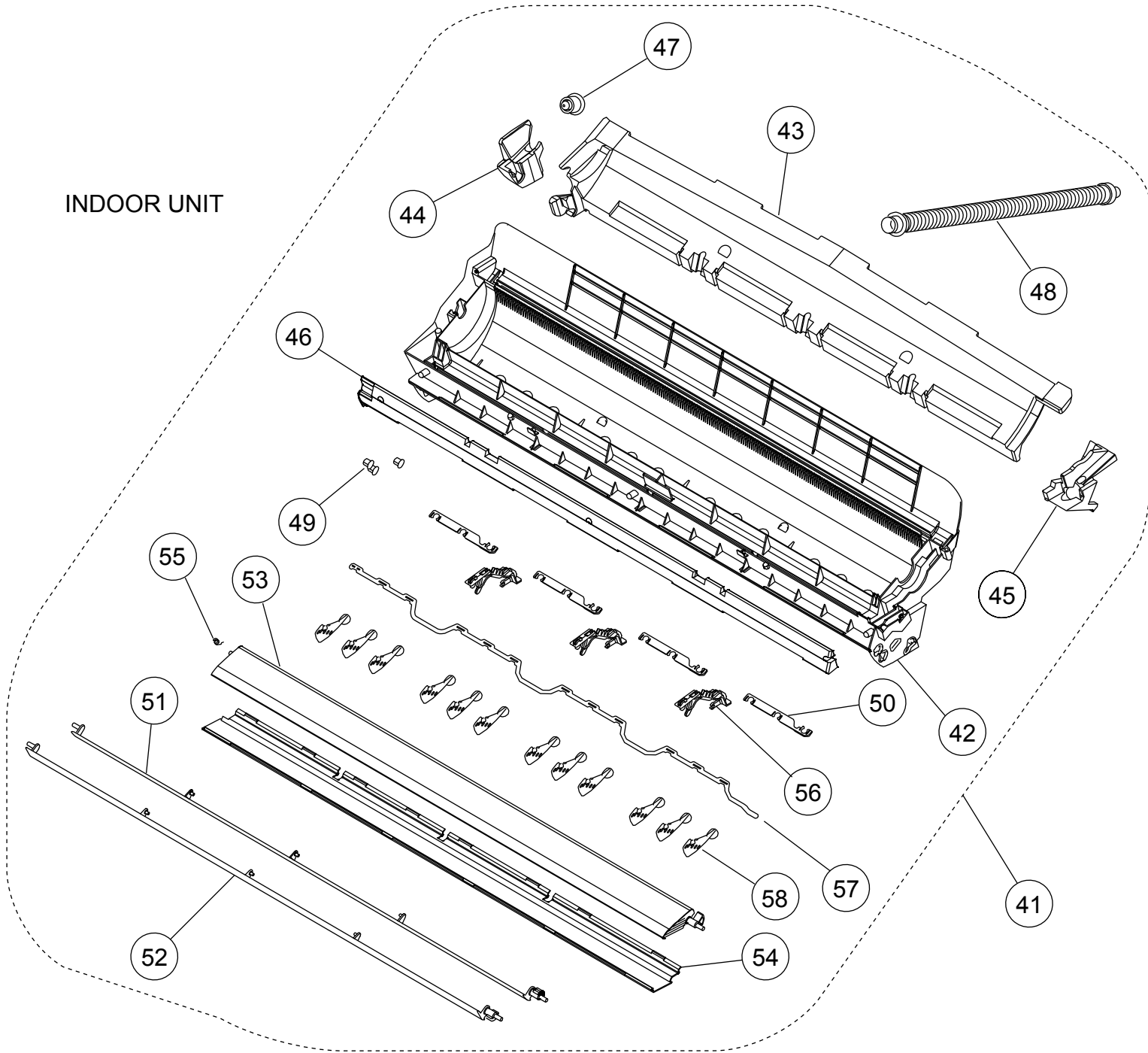

Ref	Description	Parts number
41	Casing Assy	9315331045
42	Casing	9314993015
43	Casing Cover B	9315016010
44	Casing Cover L	9315017017
45	Casing Cover R	9315018014
46	Casing Cover F	9315019011
47	Drain Cap	9367677009
48	Drain Hose Assy	9315769015
49	Bush B	9312156016
50	Spacer B	9312441013

Ref	Description	Parts number
51	Louver U	9315000019
52	Louver Z	9315001016
53	Diffuser U	9315002013
54	Diffuser Z	9315003010
55	Spring C	9314142017
56	Pillar A	9315009012
57	Joint B	9315006011
58	R and L Louver	9311997016
-	Fan Guard	9305751051
-	Fan Guard Holder Right	9315814012
-	Fan Guard Holder Left	9315815019

INDOOR UNIT

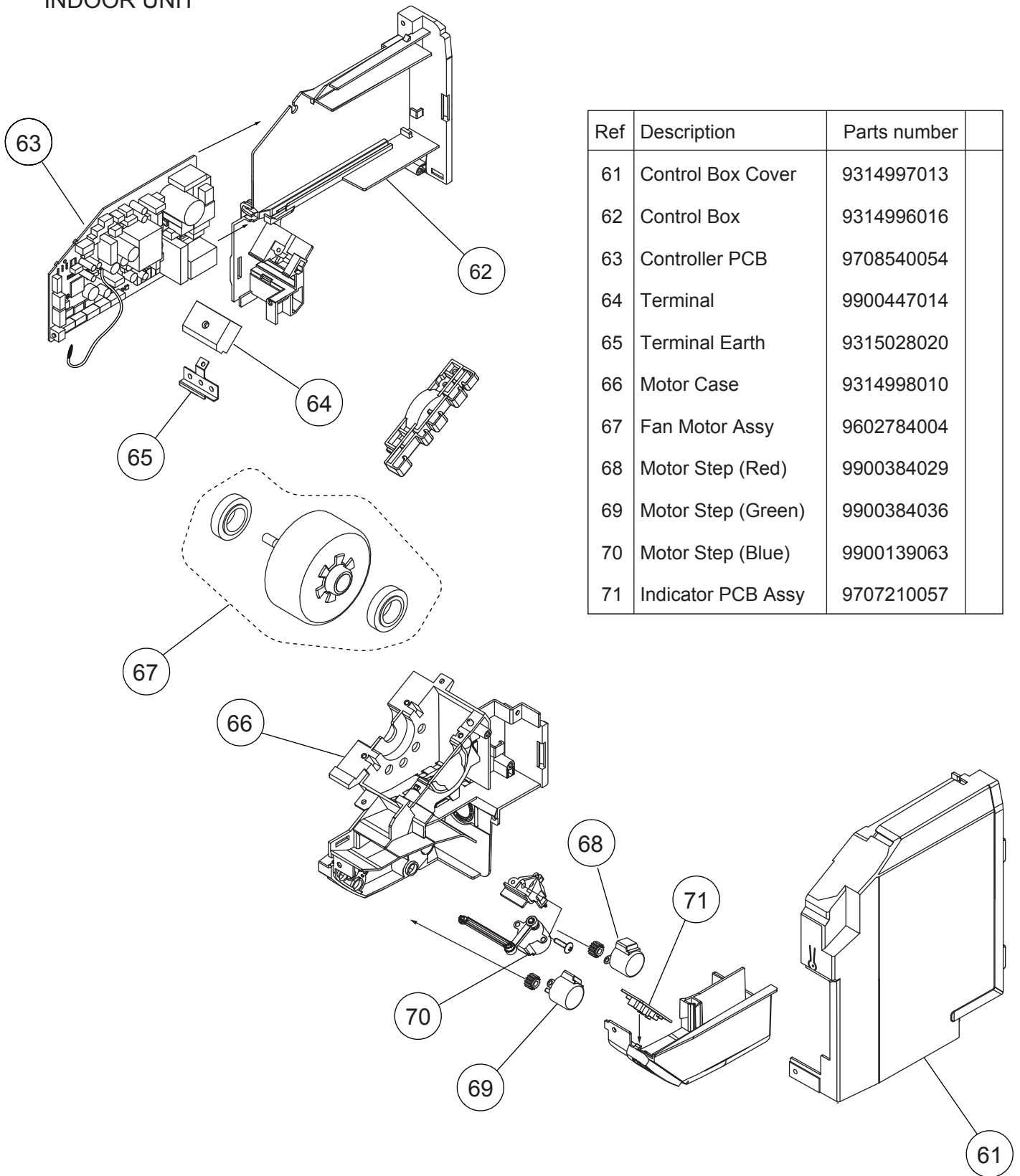

Ref	Description	Parts number
61	Control Box Cover	9314997013
62	Control Box	9314996016
63	Controller PCB	9708540054
64	Terminal	9900447014
65	Terminal Earth	9315028020
66	Motor Case	9314998010
67	Fan Motor Assy	9602784004
68	Motor Step (Red)	9900384029
69	Motor Step (Green)	9900384036
70	Motor Step (Blue)	9900139063
71	Indicator PCB Assy	9707210057

PARTS

OUTDOOR UNIT

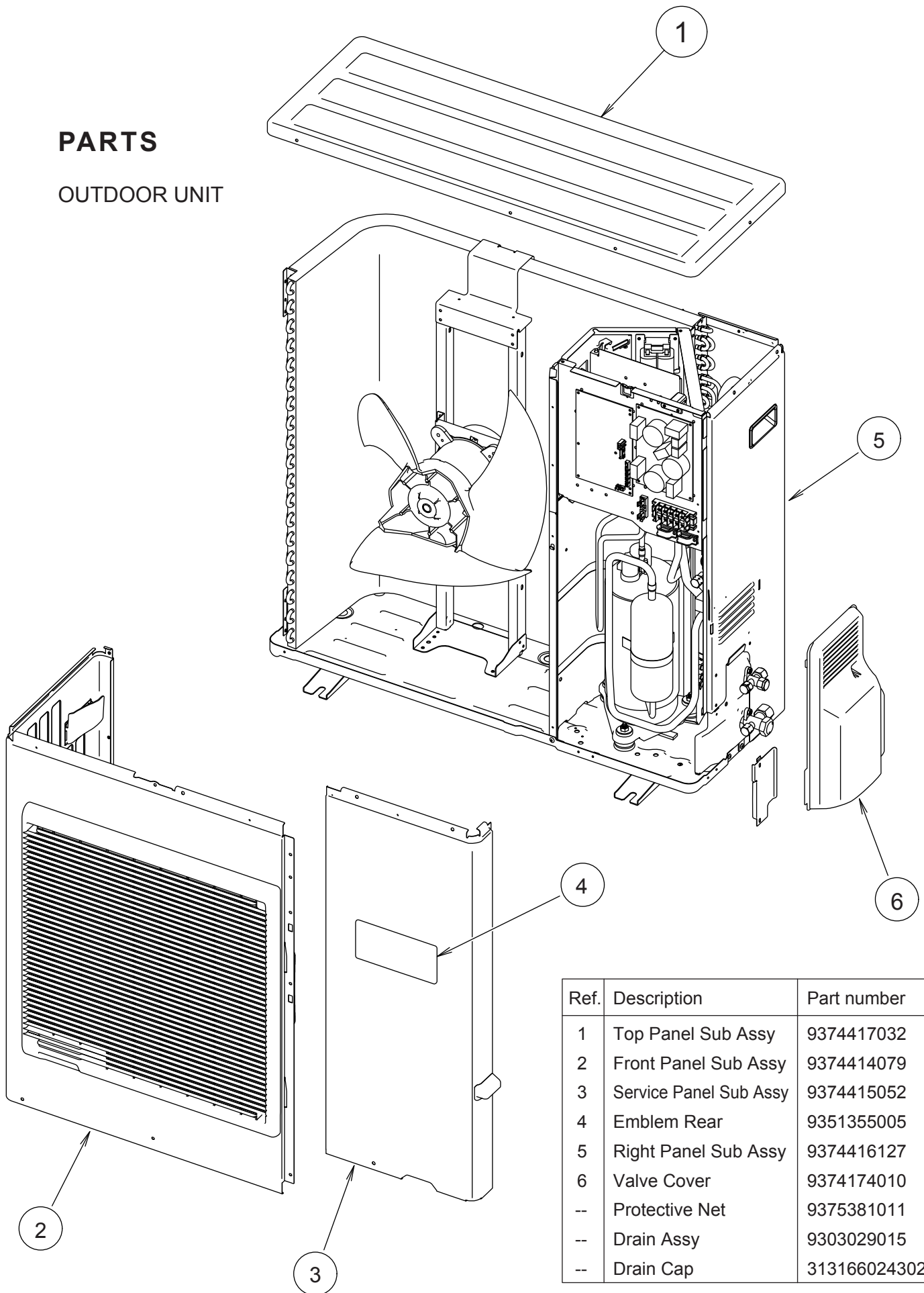

Ref.	Description	Part number
1	Top Panel Sub Assy	9374417032
2	Front Panel Sub Assy	9374414079
3	Service Panel Sub Assy	9374415052
4	Emblem Rear	9351355005
5	Right Panel Sub Assy	9374416127
6	Valve Cover	9374174010
--	Protective Net	9375381011
--	Drain Assy	9303029015
--	Drain Cap	313166024302

OUTDOOR UNIT

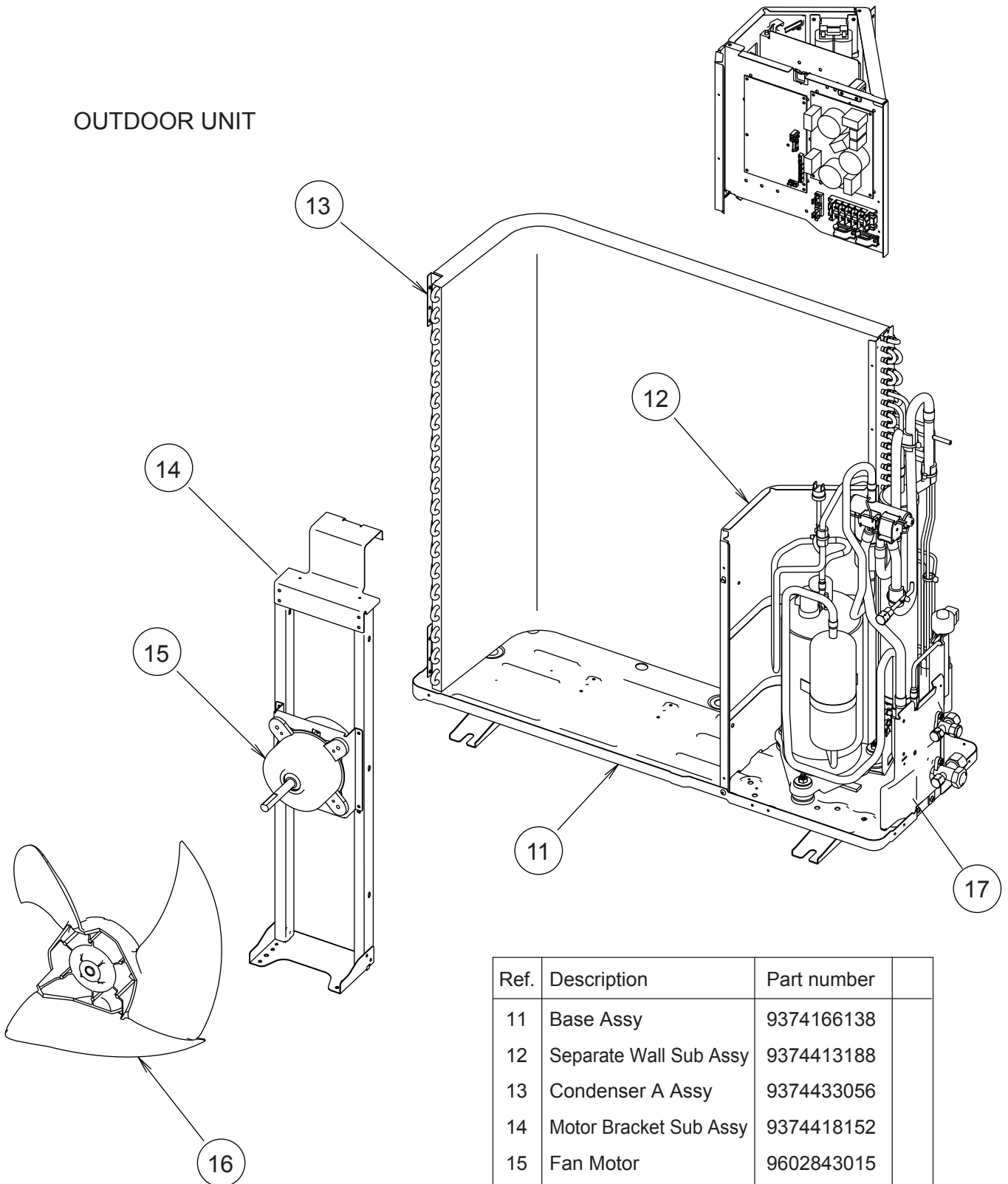

Ref.	Description	Part number
11	Base Assy	9374166138
12	Separate Wall Sub Assy	9374413188
13	Condenser A Assy	9374433056
14	Motor Bracket Sub Assy	9374418152
15	Fan Motor	9602843015
16	Propeller Fan Assy	9366378020
17	Valve Plate	9374099030
--	Compressor Cover A	9378851177
--	Compressor Cover B	9378851016
--	Compressor Cover C	9378851023

OUTDOOR UNIT

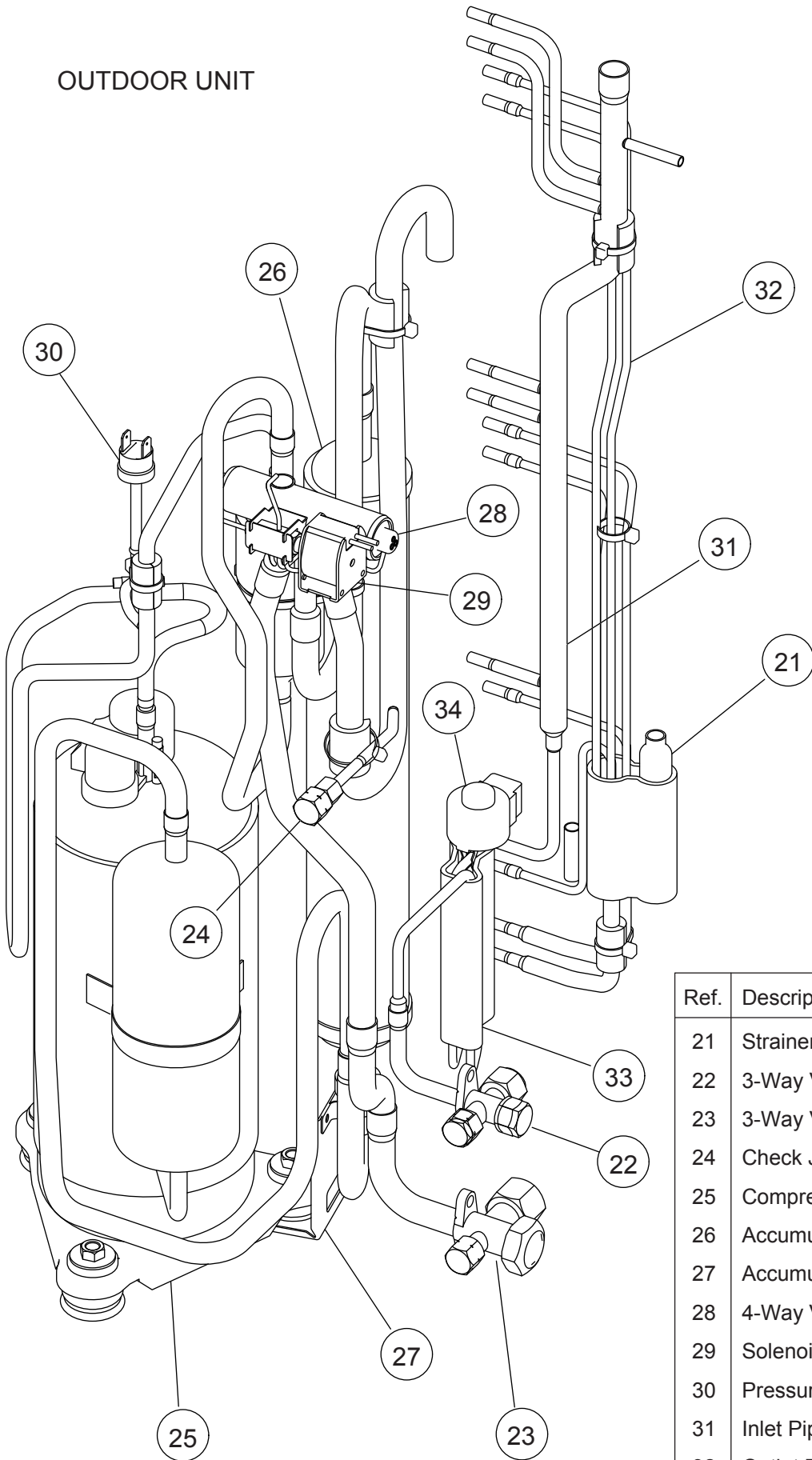





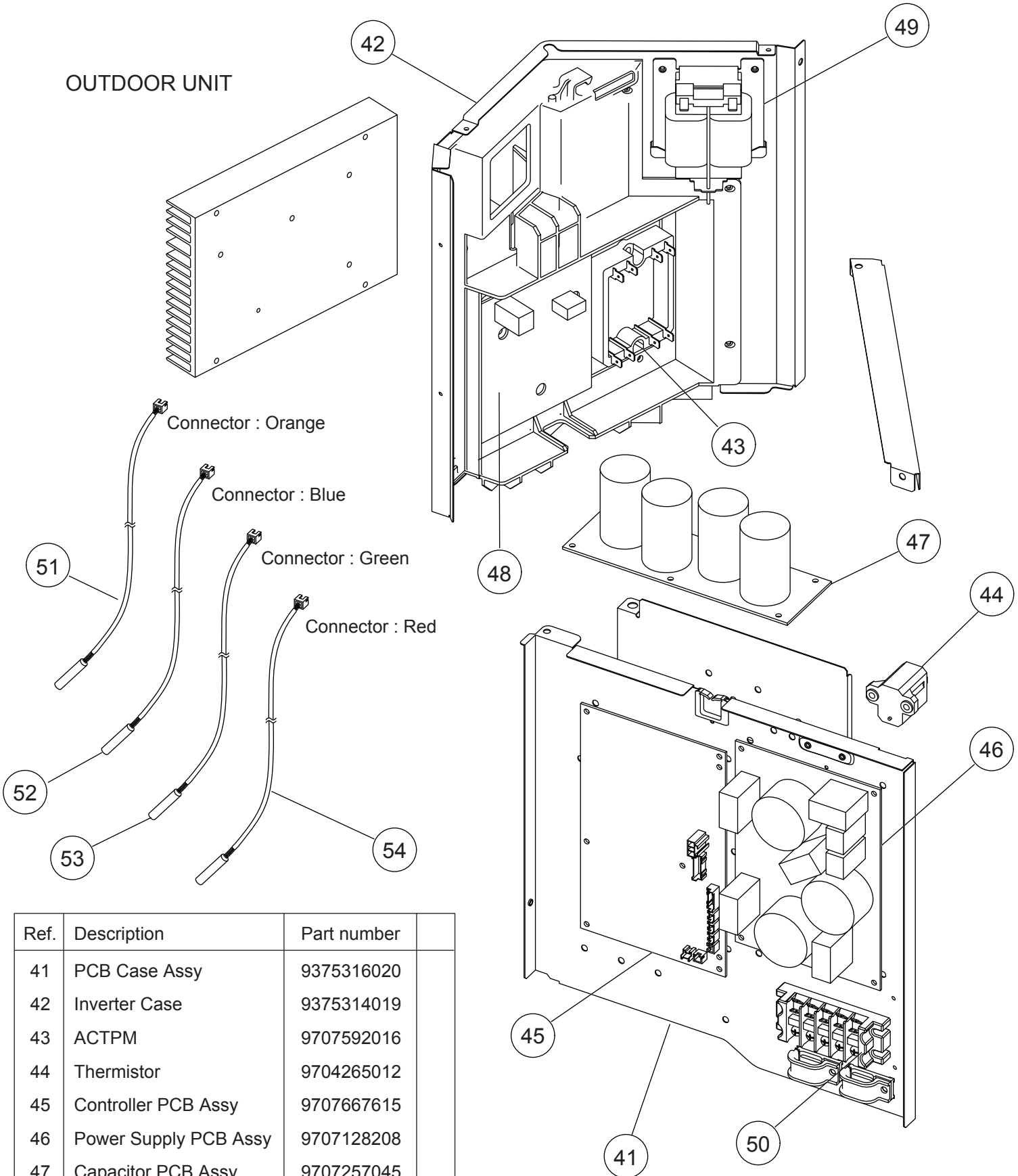

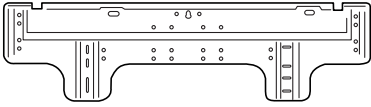

Ref.	Description	Part number
21	Strainer Assy	9372524015
22	3-Way Valve Sub Assy	9377958013
23	3-Way Valve Assy	9377959010
24	Check Joint Assy	9372802038
25	Compressor	9810135001
26	Accumulator	9385005006
27	Accumulator Support Assy	9355351003
28	4-Way Valve	9900164010
29	Solenoid	9970055034
30	Pressure Switch	9900186012
31	Inlet Pipe (Cond) A Assy	9373461067
32	Outlet Pipe (Cond) A Assy	9374266104
33	Expansion Valve Assy	9370947144
34	Expansion Valve Coil	9970095030
--	Muffler	9372369050

OUTDOOR UNIT

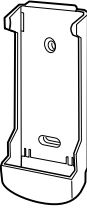

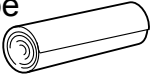
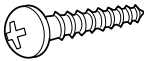
Ref.	Description	Part number
41	PCB Case Assy	9375316020
42	Inverter Case	9375314019
43	ACTPM	9707592016
44	Thermistor	9704265012
45	Controller PCB Assy	9707667615
46	Power Supply PCB Assy	9707128208
47	Capacitor PCB Assy	9707257045
48	Transistor PCB Assy	9707669060
49	Choke Coil	9900223014
50	Terminal	9900203023
51	Discharge Thermistor	9900461003
52	Outdoor Thermistor	9900463007
53	Compressor Thermistor	9900466015
54	Heat Exchanger Thermistor	9900462000

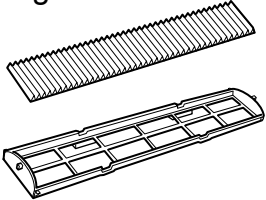
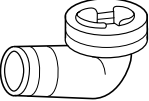
ACCESSORIES

Name and Shape	Part number
Wall hook bracket 	9315023018
Remote control 	9379219037
Remote control holder 	9305642045
Battery (penlight) 	0600185541
Cloth tape 	9310519004
Tapping screw (big) 	0700076046
Tapping screw (small) 	0700019036
Air cleaning filter 	UTR-FA13-1 UTR-FA13-2
Drain assy 	9303029015
Drain cap 	313166024302

1101G3864